

# Appendix W

## Dynamic Models

### W.2 $\triangle$ Complex Mechanical Systems

#### W.2.1 Translational and Rotational Systems

In some cases, mechanical systems contain both translational and rotational portions. The procedure is the same as that described in Section 2.1: sketch the free-body diagrams, define coordinates and positive directions, determine all forces and moments acting, and apply Eqs. (2.1) and/or (2.14).

**Example W.1 Rotational and Translational Motion: Hanging Crane** Write the equations of motion for the hanging crane pictured in Fig. W.1 and shown schematically in Fig. W.2. Linearize the equations about  $\theta = 0$ , which would typically be valid for the hanging crane. Also linearize the equations for  $\theta = \pi$ , which represents the situation for the inverted pendulum shown in Fig. W.3.

**SOLUTION** A schematic diagram of the hanging crane is shown in Fig. W.2 while the free-body diagrams are shown in Fig. W.4. In the case of the pendulum, the forces are shown with bold lines, while the components of the inertial acceleration of its center of mass are shown with dashed lines. Because the pivot point of the pendulum is not fixed with respect to an inertial reference, the rotation of the pendulum and the motion of its mass center must be considered. The inertial acceleration needs to be determined because the vector  $\mathbf{a}$  in Eq. (2.1) is given with respect to an inertial reference. The inertial acceleration of the pendulum's mass center is the vector sum of the three dashed arrows shown in Fig. W.4(b). The derivation of the components of an object's acceleration is called **kinematics** and is usually studied as a prelude to the application of Newton's laws. The results of a kinematic study are shown in Fig. W.4(b). The component of acceleration along the pendulum is  $l\dot{\theta}^2$  and is called the centripetal acceleration. It is present for any object whose velocity is changing direction. The  $\ddot{x}$ -component of acceleration is a consequence of the pendulum pivot point accelerating at the trolley's acceleration and will always have the same direction and magnitude as those of the trolley's. The  $l\ddot{\theta}$  component is a result of angular acceleration of the pendulum and is always perpendicular to the pendulum.

These results can be confirmed by expressing the center of mass of the pendulum as a vector from an inertial reference and then differentiating that vector twice to obtain an inertial acceleration. Figure W.4(c) shows  $\hat{\mathbf{i}}$  and  $\hat{\mathbf{j}}$  axes which are inertially fixed and a vector  $\mathbf{r}$  describing the position of the pendulum center of mass. The vector can be expressed as

$$\mathbf{r} = x\hat{\mathbf{i}} + l(\hat{\mathbf{i}}\sin\theta - \hat{\mathbf{j}}\cos\theta).$$

The first derivative of  $\mathbf{r}$  is

$$\dot{\mathbf{r}} = \dot{x}\hat{\mathbf{i}} + l\dot{\theta}(\hat{\mathbf{i}}\cos\theta + \hat{\mathbf{j}}\sin\theta).$$

Likewise, the second derivative of  $\mathbf{r}$  is

$$\ddot{\mathbf{r}} = \ddot{x}\hat{\mathbf{i}} + l\ddot{\theta}(\hat{\mathbf{i}}\cos\theta + \hat{\mathbf{j}}\sin\theta) - l\dot{\theta}^2(\hat{\mathbf{i}}\sin\theta - \hat{\mathbf{j}}\cos\theta).$$

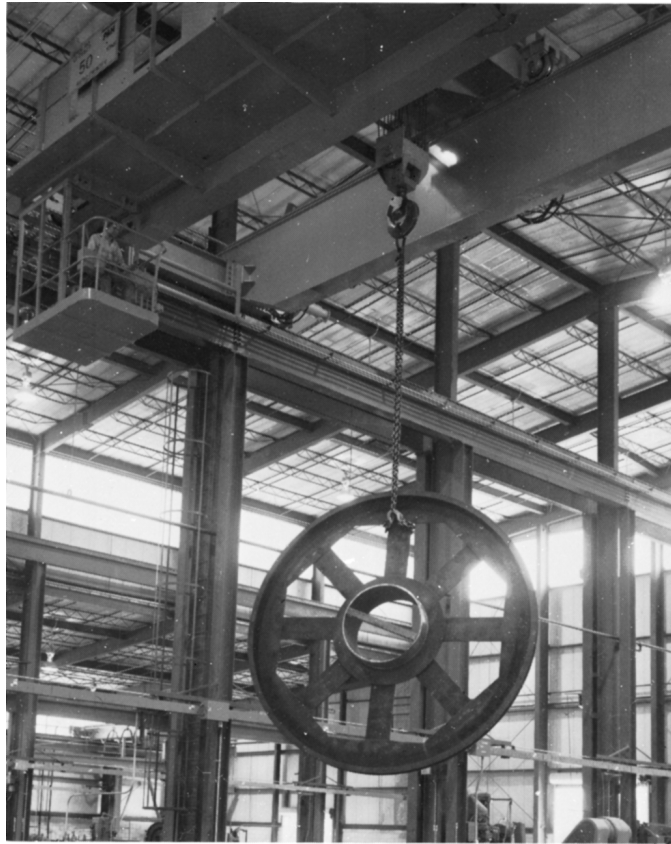

Figure W.1: Crane with a hanging load (*Photo courtesy of Harnischfeger Corporation, Milwaukee, Wisconsin*)

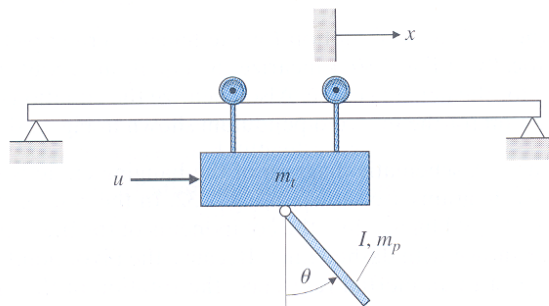

Figure W.2: Schematic of the crane with hanging load

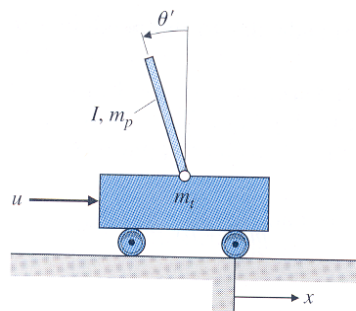

Figure W.3: Inverted pendulum

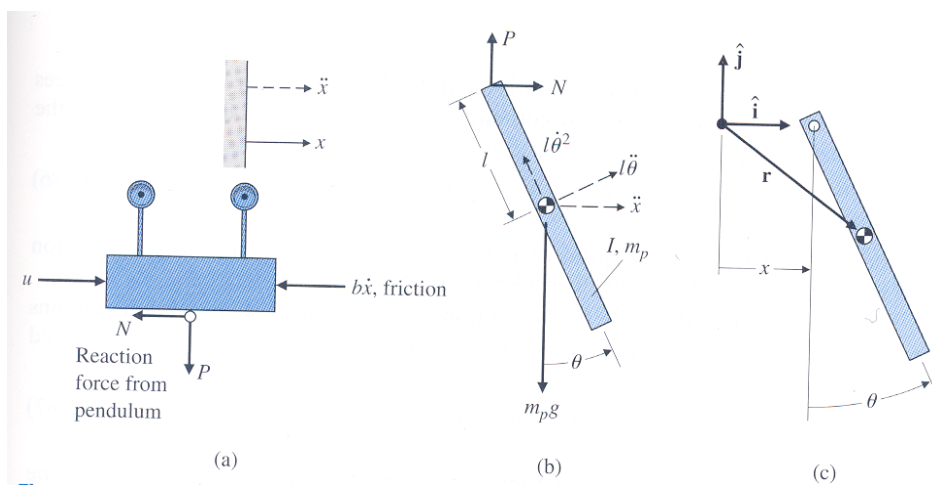

Figure W.4: Hanging crane: (a) free-body diagram of the trolley; (b) free-body diagram of the pendulum; (c) position vector of the pendulum

Note that the equation for  $\ddot{\mathbf{r}}$  confirms the acceleration components shown in Fig.W.4(b). The  $l\dot{\theta}^2$  term is aligned along the pendulum pointing toward the axis of rotation and the  $l\ddot{\theta}$  term is aligned perpendicular to the pendulum pointing in the direction of a positive rotation.

Having all the forces and accelerations for the two bodies, we now proceed to apply Eq. (2.1). In the case of the trolley, Fig.W.4(a), we see that it is constrained by the tracks to move only in the  $x$ -direction; therefore, application of Eq. (2.1) in this direction yields

$$m_t\ddot{x} + b\dot{x} = u - N, \quad (\text{W.1})$$

where  $N$  is an unknown reaction force applied by the pendulum. Conceptually, Eq. (2.1) can be applied to the pendulum of Fig. W.4(b) in the vertical and horizontal directions, and Eq. (2.14) can be applied for rotational motion to yield three equations in the three unknowns:  $N$ ,  $P$ , and  $\theta$ . These three equations can then be manipulated to eliminate the reaction forces  $N$  and  $P$  so that a single equation results describing the motion of the pendulum—that is, a single equation in  $\theta$ . For example, application of Eq. (2.1) for pendulum motion in the  $x$ -direction yields

$$N = m_p\ddot{x} + m_pl\ddot{\theta} \cos \theta - m_pl\dot{\theta}^2 \sin \theta. \quad (\text{W.2})$$

However, considerable algebra will be avoided if Eq. (2.1) is applied perpendicular to the pendulum to yield

$$P \sin \theta + N \cos \theta - m_pg \sin \theta = m_pl\ddot{\theta} + m_p\ddot{x} \cos \theta. \quad (\text{W.3})$$

Application of Eq. (2.14) for the rotational pendulum motion, for which the moments are summed about the center of mass, yields

$$-Pl \sin \theta - Nl \cos \theta = I\ddot{\theta}, \quad (\text{W.4})$$

where  $I$  is the moment of inertia about the pendulum's mass center. The reaction forces  $N$  and  $P$  can now be eliminated by combining Eqs. (W.3) and (W.4). This yields the equation

$$(I + m_pl^2)\ddot{\theta} + m_pgl \sin \theta = -m_pl\ddot{x} \cos \theta. \quad (\text{W.5})$$

It is identical to a pendulum equation of motion, except that it contains a forcing function that is proportional to the trolley's acceleration.

An equation describing the trolley motion was found in Eq. (W.1), but it contains the unknown reaction force  $N$ . By combining Eqs. (W.2) and (W.1),  $N$  can be eliminated to yield

$$(m_t + m_p)\ddot{x} + b\dot{x} + m_pl\ddot{\theta} \cos \theta - m_pl\dot{\theta}^2 \sin \theta = u. \quad (\text{W.6})$$

Equations (W.5) and (W.6) are the nonlinear differential equations that describe the motion of the crane with its hanging load. For an accurate calculation of the motion of the system, these nonlinear equations need to be solved.

To linearize the equations for small motions about  $\theta = 0$ , let  $\cos \theta \cong 1$ ,  $\sin \theta \cong \theta$ , and  $\dot{\theta}^2 \cong 0$ ; thus the equations are approximated by

$$\begin{aligned} (I + m_pl^2)\ddot{\theta} + m_pgl\theta &= -m_pl\ddot{x}, \\ (m_t + m_p)\ddot{x} + b\dot{x} + m_pl\ddot{\theta} &= u. \end{aligned} \quad (\text{W.7})$$

Neglecting the friction term  $b$  leads to the transfer function from the control input  $u$  to hanging crane angle  $\theta$ :

$$\frac{\theta(s)}{U(s)} = \frac{-m_pl}{((I + m_pl^2)(m_t + m_p) - m_p^2l^2)s^2 + m_pgl(m_t + m_p)}. \quad (\text{W.8})$$

For the inverted pendulum in Fig. W.3, where  $\theta \cong \pi$ , assume  $\theta = \pi + \theta'$ , where  $\theta'$  represents motion from the vertical upward direction. In this case,  $\cos \theta \cong -1$ ,  $\sin \theta \cong -\theta'$  in Eqs. (W.5) and (W.6), and Eqs. (W.7) become<sup>1</sup>

$$\begin{aligned}(I + m_p l^2) \ddot{\theta}' - m_p g l \theta' &= m_p l \ddot{x}, \\ (m_t + m_p) \ddot{x} + b \dot{x} - m_p l \ddot{\theta}' &= u.\end{aligned}\tag{W.9}$$

As noted in Example 2.2, a stable system will always have the same signs on each variable, which is the case for the stable hanging crane modeled by Eqs. (W.7). However, the signs on  $\theta$  and  $\theta'$  in the top Eq. (W.9) are opposite, thus indicating instability, which is the characteristic of the inverted pendulum.

The transfer function, again without friction, is

$$\frac{\theta'(s)}{U(s)} = \frac{m_p l}{((I + m_p l^2) - m_p^2 l^2) s^2 - m_p g l (m_t + m_p)}.\tag{W.10}$$

## w.2.2 Problems for Complex Mechanical Systems

1. Assume the driving force on the hanging crane of Fig. W.2 is provided by a motor mounted on the cab with one of the support wheels connected directly to the motor's armature shaft. The motor constants are  $K_e$  and  $K_t$ , and the circuit driving the motor has a resistance  $R_a$  and negligible inductance. The wheel has a radius  $r$ . Write the equations of motion relating the applied motor voltage to the cab position and load angle.

### Solution:

The dynamics of the hanging crane are given by Eqs. (W.5) and (W.6),

$$\begin{aligned}(I + m_p l^2) \ddot{\theta} + m_p g l \sin \theta &= -m_p l \ddot{x} \cos \theta \\ (m_t + m_p) \ddot{x} + b \dot{x} + m_p l \ddot{\theta} \cos \theta - m_p l \dot{\theta}^2 \sin \theta &= u\end{aligned}$$

where  $x$  is the position of the cab,  $\theta$  is the angle of the load, and  $u$  is the applied force that will be produced by the motor. Our task here is to find the force applied by the motor. Normally, the rotational dynamics of a motor is

$$J_1 \ddot{\theta}_m + b_1 \dot{\theta}_m = T_m = K_t i_a$$

where the current is found from the motor circuit, which reduces to

$$R_a i_a = V_a - K_e \dot{\theta}_m$$

for the case where the inductance is negligible. However, since the motor is geared directly to the cab,  $\theta_m$  and  $x$  are related kinematically by

$$x = r \theta_m$$

and we can neglect any extra inertia or damping from the motor itself compared to the inertia and damping of the large cab. Therefore we can rewrite the two motor equations in terms of the force applied by the motor on the cab

$$\begin{aligned}u &= T_m / r = K_t i_a / r \\ i_a &= (V_a - K_e \dot{\theta}_m) / R_a\end{aligned}$$

where

$$\dot{\theta}_m = \dot{x} / r$$

---

<sup>1</sup>The inverted pendulum is often described with the angle of the pendulum being positive for *clockwise* motion. If defined that way, then reverse the sign on all terms in Eqs. (W.9) in  $\theta'$  or  $\ddot{\theta}'$ .

These equations, along with

$$\begin{aligned}(I + m_p l^2) \ddot{\theta} + m_p g l \sin \theta &= -m_p l \ddot{x} \cos \theta \\ (m_t + m_p) \ddot{x} + b \dot{x} + m_p l \ddot{\theta} \cos \theta - m_p l \dot{\theta}^2 \sin \theta &= u\end{aligned}$$

constitute the required relations.

2. Assume the driving force on the hanging crane of Fig. W.2 is provided by a motor mounted on the cab with one of the support wheels connected directly to the motor's armature shaft. The motor constants are  $K_e$  and  $K_t$ , and the circuit driving the motor has a resistance  $R_a$  and negligible inductance. The wheel has a radius  $r$ . Write the equations of motion relating the applied motor voltage to the cab position and load angle.