

## Digital Frequency Detector & Cantilever Controller

*An all-digital solution for high-performance cantilever control*

SC Solutions' Frequency Detector and Cantilever Controller (sc-FDCT™) combines all processing required for accurate frequency detection and fast cantilever amplitude control into one module, for applications such as Magnetic Resonance Force Microscopy (MRFM) and Atomic Force Microscopy (AFM). At the heart of the system a DSP runs our patented algorithm (U.S. Patent 7,574,327 B2) that can detect frequency shifts down to 1 mHz for cantilevers with a resonance frequency of up to 25 kHz. The controller provides a phase-shifted control

signal that excites the cantilever at its resonant frequency in a positive feedback loop. An additional control loop provides amplitude control of the cantilever position signal. The all-digital implementation provides a very stable frequency estimate and control signal with low thermal drift; the stability can be further enhanced by using a high quality external clock source.

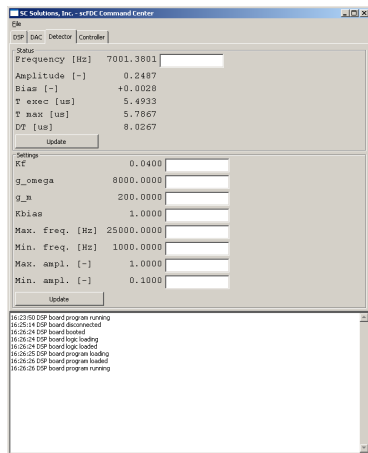

The input is a single-ended, 16-bit, 40 ns,  $\pm 2$  V ADC, with 50 Ohm impedance. As an option, the user may wish to provide additional input filtering and scaling to maximize the performance, including anti-aliasing filtering. The outputs are single-ended, 16-bit, 20 ns DACs, with a range of  $\pm 1$  V when driving a 50 Ohm impedance.

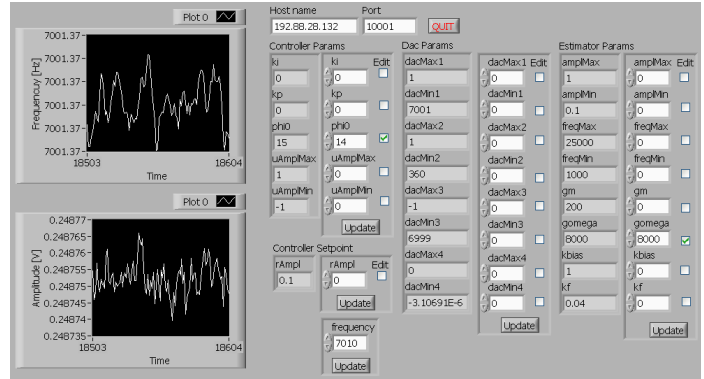

The remote access interface allows client access through a Microsoft Windows C++ client interface (other languages and platforms are available upon request). A ready-to-use LabVIEW™ VI (including source code) is provided for easy integration with other equipment. All detector/controller parameters can be changed on the fly through the remote interface, either through the included client GUI or by customer developed programs using the provided C++ or LabVIEW interfaces. Logged data, including the detected frequency and amplitude, can be downloaded in near real-time. The system can be extended by adding DSP programs, which can be loaded in a few seconds, to provide custom functionality.

The system is shipped with client software and cables, ready to go. Custom configurations and additional features are available upon request. Please contact us at sales@scsolutions.com.

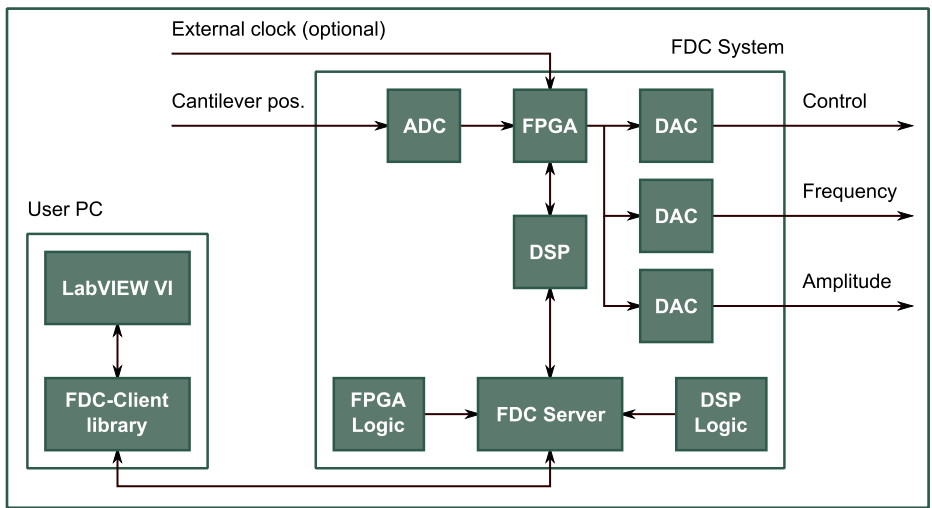

### About SC Solutions

SC Solutions, located in the heart of Silicon Valley, provides advanced control system products for a wide range of applications in the advanced materials research & manufacturing, semi-conductor, energy, defense, aerospace and infrastructure industries.